

# MTB Positioning Chart

OWNER NAME:

Full address: \_\_\_\_\_  
 \_\_\_\_\_  
 \_\_\_\_\_

Phone: \_\_\_\_\_ Email: \_\_\_\_\_

Bicycle serial number: \_\_\_\_\_

Manufacturer/Make: \_\_\_\_\_

Model: \_\_\_\_\_

Color(s): \_\_\_\_\_

A: Saddle Height: \_\_\_\_\_

B: Saddle Height Over Bars: \_\_\_\_\_

C: Saddle to Handlebar Reach: \_\_\_\_\_

D: Saddle Angle or Tilt: \_\_\_\_\_

E: Saddle fore-aft: \_\_\_\_\_

F: Saddle Brand and model: \_\_\_\_\_

G: Stem Length: \_\_\_\_\_

H: Stem Angle: \_\_\_\_\_

I: Handlebar brand and model: \_\_\_\_\_

J: Handlebar Width: \_\_\_\_\_

K: Handlebar Tilt: \_\_\_\_\_

L: Handlebar Extension Angle: \_\_\_\_\_

M: Brake Level Angle: \_\_\_\_\_

N: Brake Lever Reach: \_\_\_\_\_

O: Crank Length / Chainrings: \_\_\_\_\_

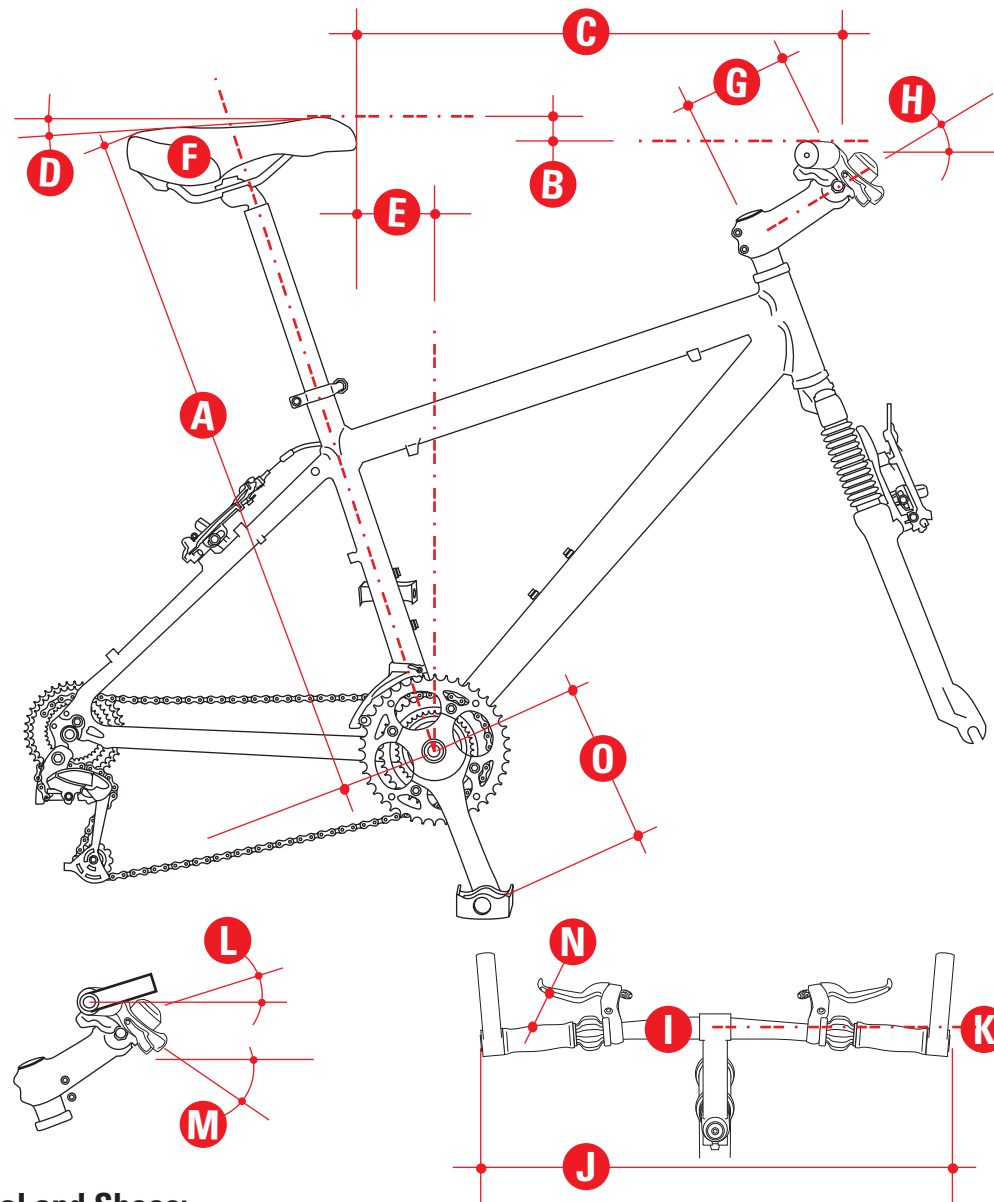

## Pedal and Shoes:

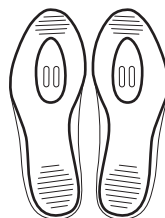

P: Pedal make: \_\_\_\_\_

Pedal model: \_\_\_\_\_

Q: Shoe size: \_\_\_\_\_

Make/model: \_\_\_\_\_

Cleat position: \_\_\_\_\_



BIKE SHOP TOOLS  
[www.parktool.com](http://www.parktool.com)